

auto electrical parts

Technical Information Sheet

Part No. 0-441-60

Durite's LED Corner Warning Lamp. SMD LED 5 x 3W. 10 Flash Patterns. IP67. E Marked R65 + R10. Supplied with SS304 mounting bracket.



Additional Information:

- Red = +VE
- Black = -VE
- Blue = Sync
- White = Flash Pattern Select (3 Seconds)

Technical Drawing (not to scale)

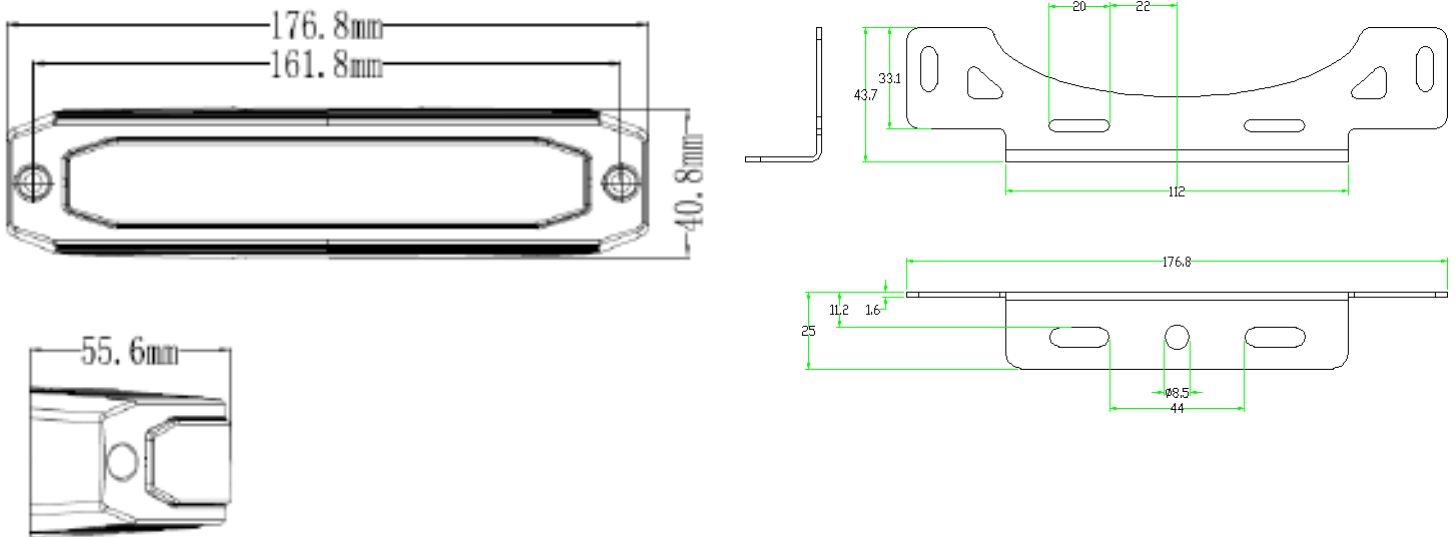

Specification

Type	Corner Warning Lamp with SS304 Bracket
Colour	Amber
Number of LEDs	5 x 3 watt SMD LED's
Voltage	12/24 volt dc
Current	0.82 amps at 12volts
Flash patterns	10
Material	Aluminium / ABS
Operating temperature	-30 ~ +65°C
Protection	IP67
Weight	0.210Kg
Dimensions	Please see above
Compliance	CE, ECE R10, R65

Flash patterns	FPM (Flashes per minute)
1. Single	100
2. Quad(left-right split)	75
3. Quint(left-right split)	60
4. Triple(left-right split)	100
5. Mega	1200
6. Double(left-right split)	75
7. Triple	100
8. Single(ECE)(1)	93
9. Single(ECE)(2)	146
10. Combine	112

The information contained in this document is correct to the best of our knowledge at the time of printing. However, specifications may change at any time without notice.